



- Ring spinning yarn break monitoring system
- Spinning IOT "WISESPIN" SYSTEM
- Electronic spindle
- Intelligent auto-doffing system
- Spandex break monitoring system
- Electronic drafting system
- Electronic lifting system

SHENZHEN JADEYO INTELLIGENT CONTROL TECHNOLOGY CO.,LTD

☎ 0755-27906180

🌐 <https://www.jadeyo.cn> <https://www.wisespin.cloud>

📍 Building 2, Phase II, Fenda Science Park, Baoyuan Community, Shiyuan Street, Bao'an District, Shenzhen



Wisepin cloud

📱 Android Download    🍏 iOS Download

## RING SPINNING WORKSHOP INTELLIGENT INTEGRATED SOLUTIONS

SHENZHEN JADEYO INTELLIGENT CONTROL TECHNOLOGY CO.,LTD

深圳市嘉友智控科技股份有限公司

# Enterprise honor



# ABOUT US

Shenzhen Jadeyo Intelligent Control Technology Co.,Ltd, founded in 2015, is a national high-tech and Shenzhen specialized, refined and innovative enterprise, committed to provide hardware, software and consulting services for intelligent modification of textile industry.

Jadeyo has always been adhering to the core values of "devoting to research and development with customer-driven orientation, to create maximum value", and assisting to build first-class intelligent manufacturing workshop.

Jadeyo has a first-class software and hardware development team, which integrates research and development, production, sales, service and system integration, and fully masters the core technology of digitalization, networking and intellectualization of the intelligent spinning system of the Internet of Things.

Jadeyo products sell well in more than 20 provinces, autonomous regions and municipalities and many countries in Southeast Asia.

**VISION** Focus on intelligent manufacturing and become the leader of the subdivided industry.

**MISSION** Adhere to technology innovation, to empower traditional manufacturing industry.

**VALUES** Customer-driven research and development, create maximum value.

**POLICY** Leading technology, superior performance, high quality and high value performance, consummate service.

**SPIRIT** Innovation changes the world, hard work wins the future, struggle casts brilliant.

ADHERE TO TECHNOLOGY INNOVATION  
EMPOWERING TRADITIONAL MANUFACTURING

Approx.100 patent certificates and software Copyrights

## 9 Reasons For Choosing Jadeyo

### Intelligent manufacturing

Product research and development covering each process of spinning intelligent monitoring - intelligent doffing - intelligent piecing - intelligent transportation - intelligent management, worth expecting, the systems are compatible, interconnected and worth having.

### Global leading

the installation capacity of individual spindle yarn break monitoring has exceeded 18 million spindles, wisepin cloud platform online more than 300 spinning mills, intelligent ring frame with electronic spindle is originated in the world.

### Innovative design

Stand in Shenzhen, independent research and development involving electronics, machinery, industrial Internet and other fields, Various technologies are integrated and continuously innovated.

### Professional team

More than ten years focus on intelligent spinning products research and development, the expert team and technical personnel reached hundred.

### High value performance and advantage

master the core technology, set product independent research and development, automatic production line, full-time sales and professional service, product with high quality and high value performance.

### Customized services

Customer demand-oriented, modular product design, on-demand selection, can meet with different needs, and different enterprises.

### Customer orientation

We always put customers first place, to provide the most satisfactory service.

### Global layout

Multi-language products, export to many countries and regions, in Indonesia, Bangladesh, Vietnam, Pakistan, Malaysia etc, we have full-time after-sales engineers.

### Economic assistance

Product + financing + subsidy service model, provide financial leasing and policy subsidy services for our products.

**LEADING TECHNOLOGY-SUPERIOR PERFORMANCE-HIGH QUALITY AND HIGH VALUE PERFORMANCE-COMPLETE SERVICE**

## RING SPINNING WORKSHOP INTELLIGENT INTEGRATED SOLUTIONS

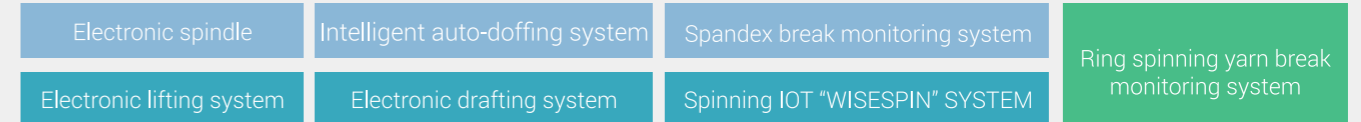

Every solution integrated into cloud edge structure, can be randomly combined and controlled.

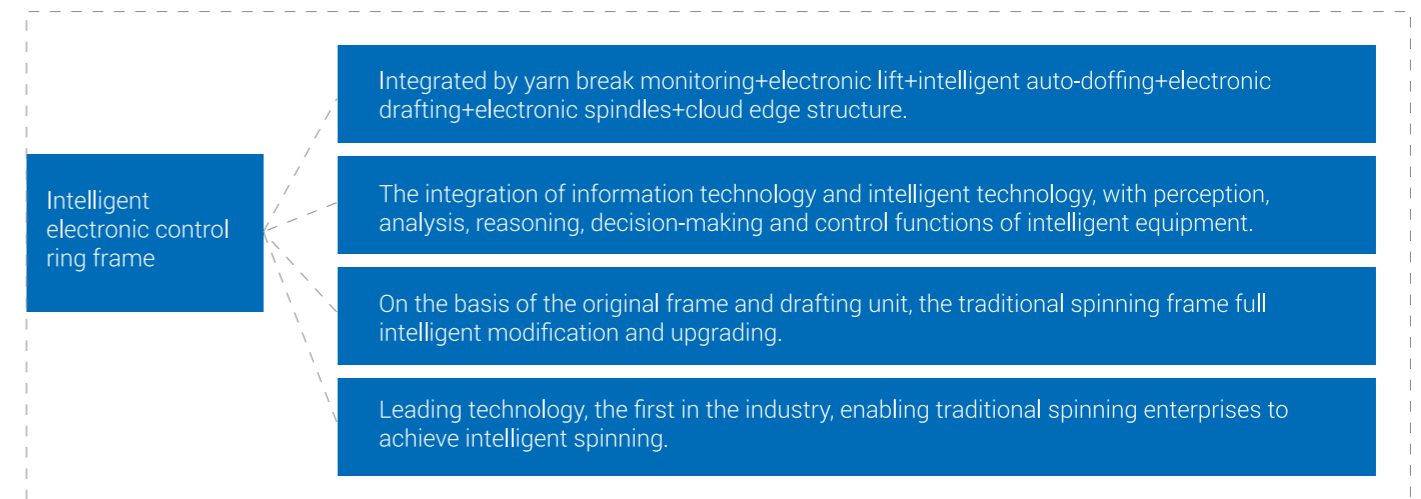

## Cloud edge structure

### Integrated design of cloud edge:

Configure edge computing industrial control computer, strengthen decision-making and control of equipment, multi-screen integration, centralized control of electronic drafting, electronic lifting, individual spindle monitoring, electric spindle, auto-doffing and other systems.

### With "wisepin Cloud" process library:

Deep digging data, management and equipment value, Equipped with WIFI or 4G network module, with wireless networking function.

### Ethernet interface:

All spinning frame related production and quality data are integrated into the single chip microcomputer, and the touch screen is reserved for the process Ethernet interface, which is convenient for users to follow-up network management and access different MES systems through Ethernet.



### Self-developed embedded system:

Self-developed ETHERCAT/CANOPEN IO module, combined with distributed bus control, making the wiring flexible, high bandwidth, high reliability, easy to expand and other characteristics.

### Flexible expansion:

Optional power, temperature and humidity, vibration, negative pressure and other expanded sensing equipment, support real-time monitoring and early warning; It supports the setting of predictive models such as energy consumption analysis, motor and mechanical wave anomalies based on the wisepin cloud and its edge computing.

### Remote operation and maintenance:

Remote control based on multi-authorization mechanism, supporting remote identification, diagnosis and correction of equipment faults through Wisepin Cloud.

# Ring spinning yarn break monitoring system

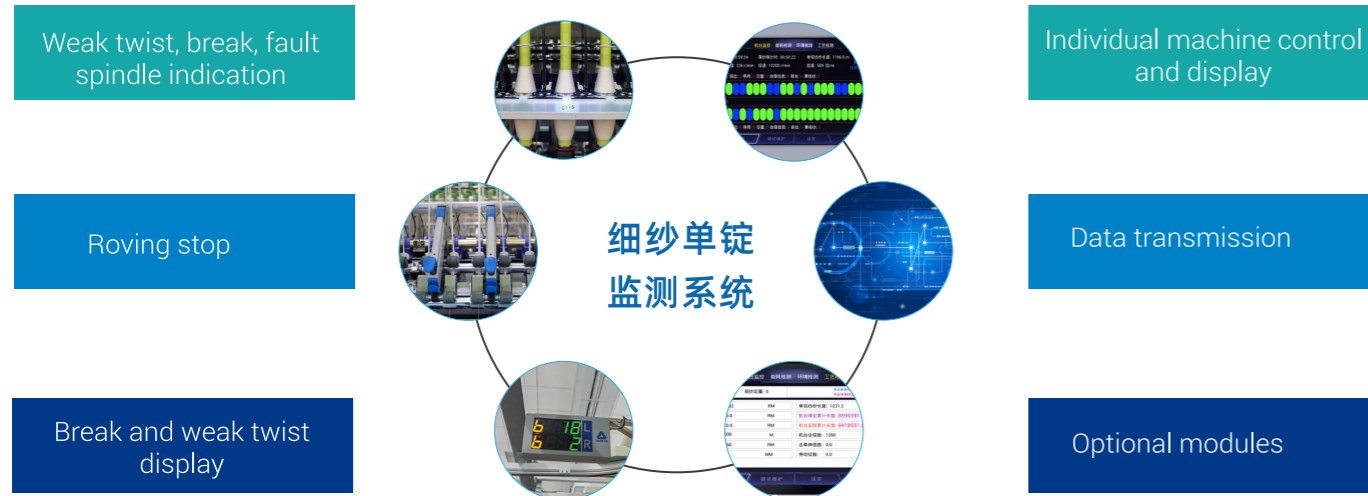

## Use contrast

No.	Item	After Installed	Specification
1	Machine qty/spinner	Improve 20%	Reduce ineffective patrolling, no wrapping, leisurely operation.
2	Efficiency	Improve 1.5%	Find break in time, reduce empty spindles
3	Waste	Reduce 70%	With roving stop
4	Break/1000 spindles/hour	Reduce 2%	Find backward spindles in time
5	Weak twist	Eliminate	Find weak twist spindles in time
6	Apron & cots wrapping	Eliminate	With roving stop
7	Suction fan energy consumption	Reduce 20%	Inverter regulates suction fan power based on break quantity Optional module

## System function

- ① PCBA allocates spindle identification automatically, each section wireless connection, convenient installation and maintenance.
- ② Sensitive and compact optical sensor, convenient for spinner and mechanic piecing yarns and replacing parts.
- ③ Compact roving stop device suitable for parallel and V-shape drafting, installation and maintenance uncomplicated.
- ④ After break, within 5 seconds roving stop device will work.
- ⑤ LED display and Android smart display provide instant maintenance guidance for spinner and mechanic.
- ⑥ System self-adaption, software version update and parameter modification can be accomplished online by self-adapting, or one-click on cellphone/PC.
- ⑦ AI will adjust parameter and signal voltage automatically, according to optical signal from traveller and illumination strength.

## Yarn Break Monitoring Benefits

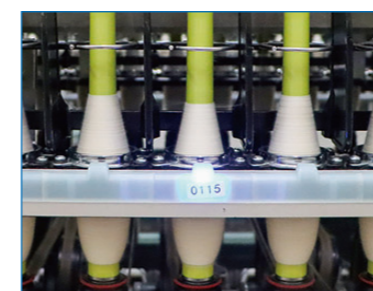
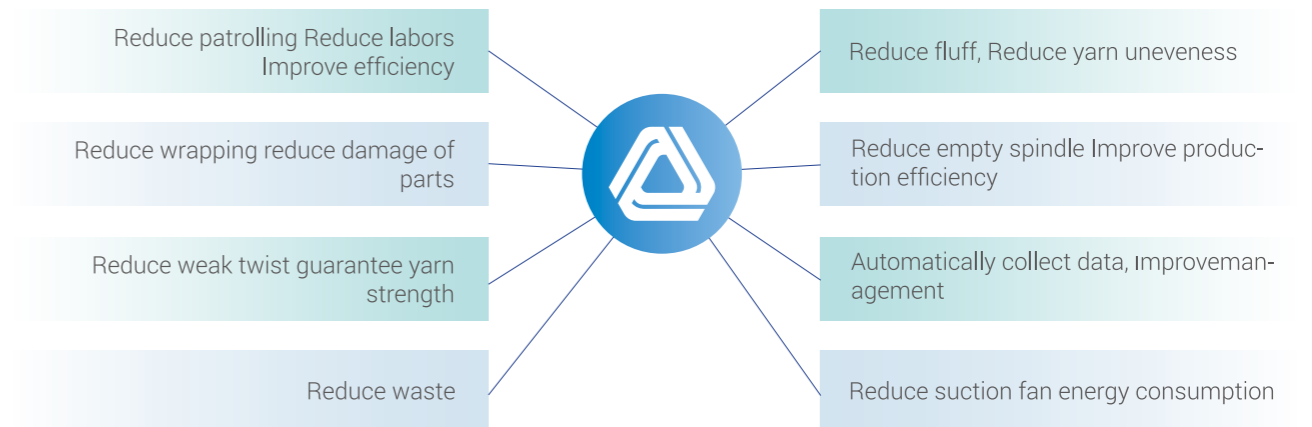

Weak twist, break, fault spindle indication



Roving stop



Break and weak twist display

## Electronic spindle

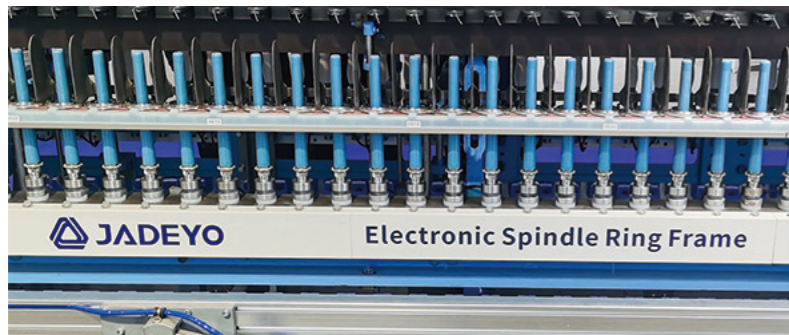

### peculiarity

#### ◎ Save maintenance

1.1 Cancel main shaft, rolling plate for belt, spindle belt and other transmission mechanism, eliminate related parts maintenance costs. 1.2 The vibration source disappears, the frame does not out of shape, and the frame no need adjustment. 1.3 High speed and high performance flat bottom aluminum spindle design, spindle running without spindle radial force, longer operating life and refueling cycle.

#### ◎ Save energy

1.1 High efficiency DC brush-less motor. 1.2 Motor direct drive. 1.3 Broken end automatic stop. 1.4 Spindle speed curve optimization.

#### ◎ Increase productivity

1.1 Spinning tension and spindle speed closed-loop feedback, reduce breakage, improve productivity. 1.2 The maximum spindle speed mode can be set. 1.3 Can set the minimum break spindle speed mode. 1.4 The whole machine runs smoothly without vibration, which is conducive to high-speed operation. 1.5 High consistency of spindle speed, improved consistency of spinning tension, which is conducive to speeding up the frames.

#### ◎ Improved quality

1.1 Accurate closed-loop control, high consistency of spindle speed, greatly reduced CVb%, twist CV% and strength CV% between bobbins. 1.2. Eliminate the influence of a spindle stop or abnormality in a group of spindles on the twist of neighboring spindles. 1.3 Eliminate repetitive twisting of piecing and reduce strong twisting yarn. 1.4 Eliminate the turbulence of the frame, reduce the breaks and defects, specially and obviously reduce occasional yarn defects,

#### ◎ Convenient process

1.1 Yarns with different twist or twist direction can be different by different sections of the same frame. 1.2 The spinning process of spindles can be set accurately for spindle rotation directions and improving the auto-doffing ends retention rate.

#### ◎ Improve the environment

1.1 Cancel the main shaft and rolling plate, reduce the accumulation of fluffs under ring frame. 1.2 Individual motor drive, noise reduced, greatly improve environment for communication.

## Electronic drafting system

### Drafting upgrading:

1.1 Front, middle, rear rollers individual controlled by servo motors, satisfy ordinary yarn and other special yarn production. 1.2 Gear end with oil can, Clean appearance, no gear exposed.

### Process improvement:

1.1 Use single chip microcomputer and electronic program to control the operation and process of the roller, easy to change spinning. 1.2 High precision of control, fast and convenient for adapting to the requirements of different draft speed ratios. 1.3 The spindle speed can be adjusted by frequency conversion system;

### Hardware performance:

1.1 High drive system efficiency, synchronous belt drive smooth, no noise. 1.2 Servo controller, motor heat dissipation with good performance. 1.3 Gear oil can durable, good sealing without oil leakage.

### System functions:

1.1 Synchronous function of spindle, roller and ring plate in case of power failure, lightning strike and voltage break. 1.2 When the drafting ratio and yarn twist are abnormal, can identify and alarm in time. 1.3 When doffing, has the function of changing twist and changing count to solve the problem of low twist and improve the rate of end retention.

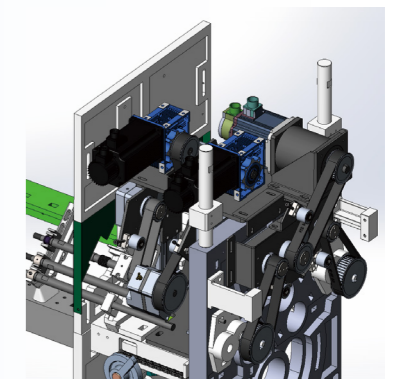

## Electronic lifting system

### Electronic process:

1.1 The spindle speed, variety and forming diameter can be set on the touch screen. 1.2 According to the variety, the self-developing forming algorithm automatically calculates the CAM curve suitable for the current variety. 1.3 The yarn coils automatically calculated to meet the needs of keeping the yarn on the spindles, reducing the start breaks and reducing the manual cleaning for auto doffing.

### Reduce broken ends:

1.1 9 sections of speed can be set according to the height or length ratio, and the spinning tension is constant to reduce broken ends. 1.2 Set the ingot speed curve reasonably through the frequency conversion system and apply the ingot speed climbing function to effectively reduce the broken end. 1.3 Yarn speed and time can be configured to prevent breaking at boot. 1.4 Stable lifting of the steel collar plate, there are optimization actions such as drawing yarn, dotting back up, tube top yarn, etc., greatly reducing the broken end;

### High efficient for winding:

1.1 Small yarn bobbin, yarn wrapping precise control, easy for winder to find ends. 1.2 The yarn is formed evenly to avoid yarn breakage and coil drop.

### Rich options for control:

1.1 Start spinning height and the height of small motion can be adjusted by touch screen. 1.2 Yarn coil size adjustable by touch screen. 1.3 The 2 doffing methods: fixed length of yarn or height limit of ring plate parameters can be adjusted.

### Ensure safety:

1.1 Support power shut down, emergency stop and other abnormal stop situations without overlapping yarn or breaks. 1.2 Electronic brake to ensure stop will not cause fire alarm or weak twist.

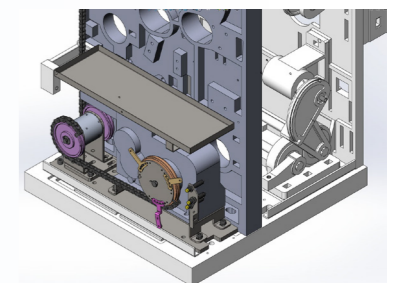
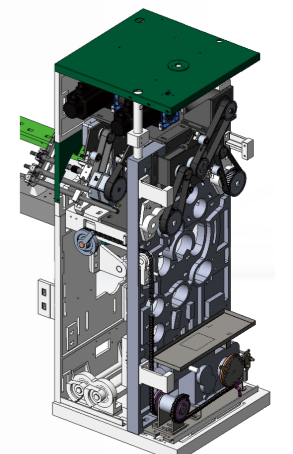

# Intelligent auto-doffing system

Jadeyo auto-doffing system is an innovative system that supports retaining the original spindles, based on self-developed bus distributed embedded hardware and software, integrated cloud edge control and IOT design, suitable for all kind of ring frames modifications.



## Features

- ① **Product type**  
Pendulum type, translation type, to meet the needs of different space and different frame modification.
- ② **Vertical steel belt**  
Active, efficient and stable transmission, easy adjustment, low noise. The use of high quality steel belt, tensile non-deformation, to ensure the long-term positioning accuracy for the bobbins.
- ③ **Unc hange spindles**  
Based on dual-mode design, can choose the modification strategy not change spindles, which greatly reduces the auto-doffing investment,and the performance is basically close to the application effect of changing the aluminum spindles.
- ④ **End retention optimization**  
Equipped with a proprietary electronic lifting program for the spindle for further balance the yarn tension, and the start break is better than the industry standard.
- ⑤ **Short frame into series**  
Support 2 (or more) short frames into series after installing a set of auto-doffing device, reduce investment, save space, reduce operation, labor and save doffing time.
- ⑥ **Space optimization**  
Optimized air frame, lift shaft, side guard board and other patented components, support the auto-doffing modification for narrow workshops.
- ⑦ **Fast implementation**  
Based on the upgrade of the original spindle, keep the position of the structure and main shaft unchanged, ensure the stability of the original machine, and reduce the installation period.
- ⑧ **Leading indicators**  
3-4 minutes of total action, managing time 18-25 minutes,intubation rate 100%,extubation rate 100%,r etention rate  $\geq 98\%$ .
- ⑨ **Wide application**  
Meet most ring frame modifications, suitable for FA506, F1508, JWF1510, JWF1516, BEST BS516, BS538, SXF1568B and EJM FA503, FA507, DTM129, EJM128K, EIM462 and other models.

100% Intubation rate   100% Extubation rate    $\geq 98\%$  Retention rate

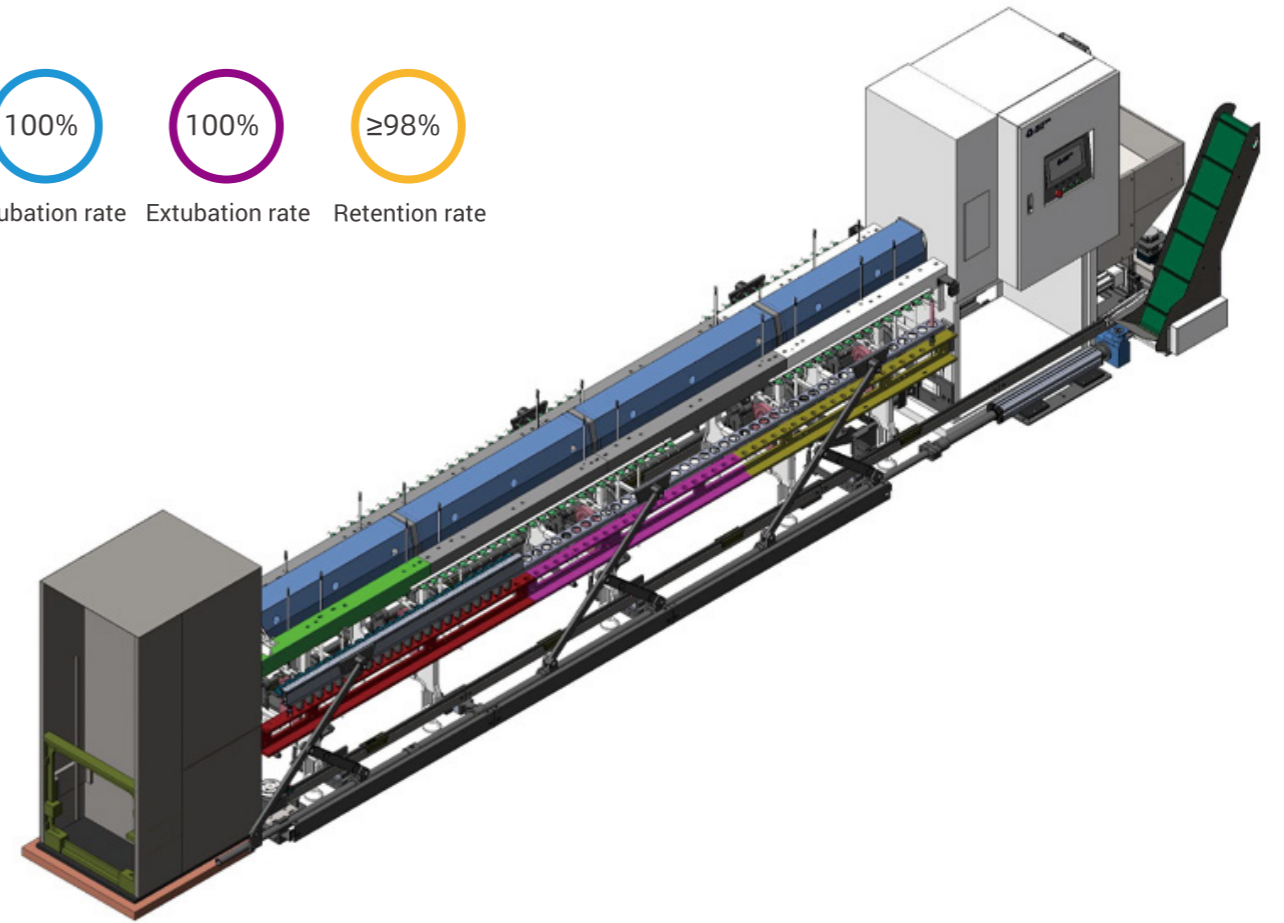

# Spinning IOT “WISESPIN” SYSTEM

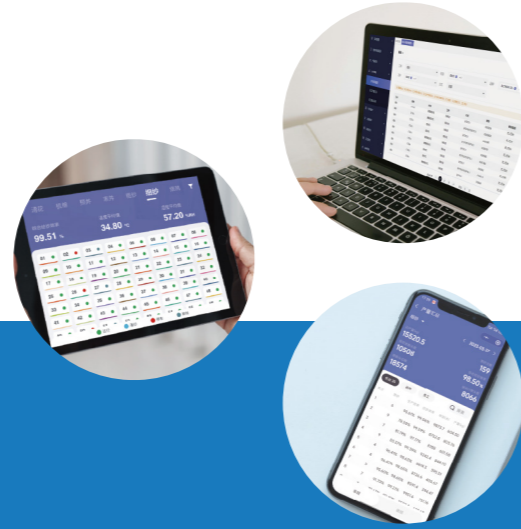

The platform supports the intelligent manufacturing execution system of all processes in the whole spinning process, including blowing, carding, pre-drawing, drawing, combing, combining strip, roving, ring spinning, winding and double twist. The platform relies on AIOT equipment, cloud computing and intelligent APP, and is based on four functional combinations of data aggregation, multi-role collaboration, visual analysis and intelligent decision-making. Using data and algorithms to help spinning enterprises improve capacity utilization, optimize manpower efficiency, shorten production cycle, reduce inventory overstock, transparent spinning process, and realize data-driven lean manufacturing.

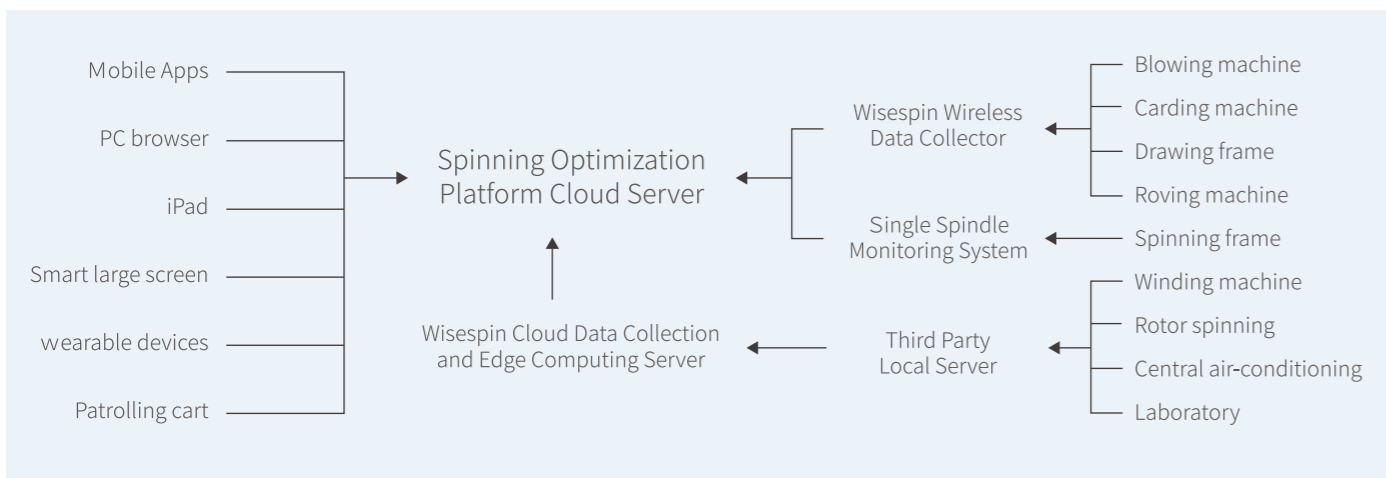

## Value of Wisespun Cloud

- Dynamic production display
- Seamless process
- Shorten the production cycle
- Reduce inventory overhang
- Precision piece rate wage
- Increase capacity utilization rate
- Optimize manpower effectiveness
- Process and production quality inspection

## Spinning Full Process Wisespun MES

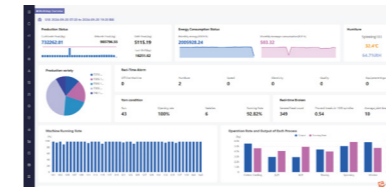

Workshop overview

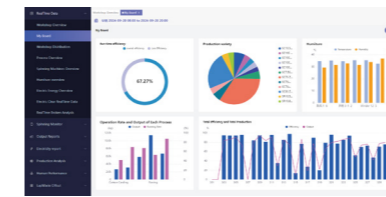

Real-time kanban

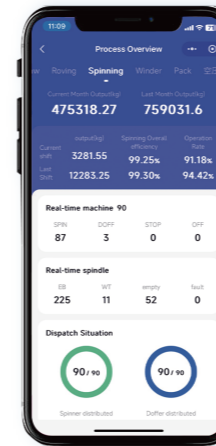

Process overview



Temperature and humidity monitoring

### Equipment monitoring

Real-time monitoring of key parameters of each process (speed/spindle speed/voltage/breaks/1000 spindles/hour....) Abnormal situations are displayed on the large screen in the workshop in time, and messages can also be reminded through APP in smart devices.

### Environmental monitoring

The environmental monitoring system is connected to the industrial Internet of Things temperature and humidity collection equipment deployed in each area of the workshop, supporting the visualization and real-time status monitoring of environmental data.

### Energy consumption management

The energy consumption management system diagnoses and analyzes the operating status of the equipment through real-time power consumption data collection, and quickly calculates the operating efficiency and energy consumption of the equipment.

### Manpower effectiveness

Flexible and convenient calendar scheduling, salary and output, quality, number of machines and other indicators related to automatic calculation, eliminate manual calculation, improve information transparency and employee trust.

### Order management

Present all execution processes of orders in real time, through process management, progress query, etc. to accelerate production execution visible and controllable, reduce communication costs, and ensure delivery time.

### Process optimization

Support convenient query and trace of each product process, change equipment process parameters, intuitive response characteristics of each device, fast analysis equipment performance of related varieties.

### Quality control

Contains the quality data of the whole spinning process. The system is connected to the laboratory equipment through the industrial Internet of Things communication. According to the quality process parameters of the online operation spinning equipment, real-time data monitoring and tracking are carried out and abnormal information is reported in time.

### Warehouse Storage module

The warehouse management system can perform inventory management operations independently, also can be used in combination with documents and vouchers of other systems to provide enterprises with more complete and comprehensive business processes and financial management information.

### Waste management system

System can classify and record the waste materials of different processes, and the cotton distributor can clearly understand the list of materials of the waste to organize the material distribution plan.

### Raw material palletizing

It mainly includes raw material data management module and distribution scheme management. Distributor can select and deliver material distribution reasonably according to the waste and raw material data management.

### Order management

Present all execution processes of orders in real time, accelerate production execution visible and controllable through process management, progress query, etc., reduce communication costs, and ensure delivery time.

### Cloud Academy

Wispun cloud system audio and video tutorial, software and hardware fault inspection, analysis, elimination methods. As a department of knowledge base, to provide industry information and policy documents to the management or certain people.

# Full bobbin yarn quality trace system

## Ring-Winding Integrated Yarn Quality Tracing

Relying on JADEYO spinning individual spindle yarn break monitoring system, auto-doffing system, wisepin cloud MES system, integration of winding yarn cleaner, deployment of spindle position identification and detection device, JADEYO automatic bobbin and spindle position tracking system brings a unique alarm and analysis system for the quality control of spinning mills, realizes process optimization and defect yarn traceability, and forms a closed loop quality control of spinning yarn to winding. Reduce the generation of poor quality yarn, reduce winding defects, improve yarn quality, improve work efficiency, and reduce the overall cost. The system is specially helpful for improving the quality of multi-variety and differentiated yarns.



### Product highlights

#### Trace and block fault spindle of spinning frame

JADEYO spinning individual spindle yarn break monitoring system with the roving stop device can receive information from the winder about the defect yarn, such as excessive yarn knots, regular unevenness, etc., and the roving stop device can immediately block the problematic spinning spindles to continue spinning. At the same time, the LED of the JADEYO yarn individual spindle yarn break monitoring system sends a signal on the spindle with quality problems, and guides the maintenance worker to accurately reach the spindle in the fastest way. This defect prevention system can significantly reduce the loss of spinning materials, the cutting and alarm of the yarn cleaner, realize the yarn clearing function on the ring frame.

#### Ring frame maintenance basis

Through wisepin Cloud can query and analyze the quality data of each frame and each spindle, can fully check the production quality status of the spinning frame, clearly help to find the ring frame abnormal spindle positions, support to accurately determine whether the ring frame needs to be maintained and in which way for maintenance. Such as single spindle maintenance, whole frame maintenance, small and big area adjustment.

#### Yarn quality optimization

By connecting to the wisepin cloud, it can optimize the analysis of the production state of the spinning, provide the yarn forming report, correlate the quality data provided by the winder cleaner and the yarn breakage data, and optimize the quality and speed curve of the ring frame on this basis, so that the spinning machine can reduce the breakage and achieve higher output.

# Spandex break monitoring system

The patented product generates different pulse signals from the distinct induction mode of magnet and Hall switch, which triggers the control module to output electrical signals to the roving stop feeding device to operate, so as to convert the manual sensory monitoring into electromechanical automatic control induction monitoring; Once the yarn is broken, the signal will be sent out immediately, and the roving stop indication will be completed instantly, which avoids the empty core yarn, reduces the occurrence of quality accidents and waste of raw materials, enhances the quality and reputation of the spinning mill.



## Ring Spinning and Spandex Monitoring System Sketch

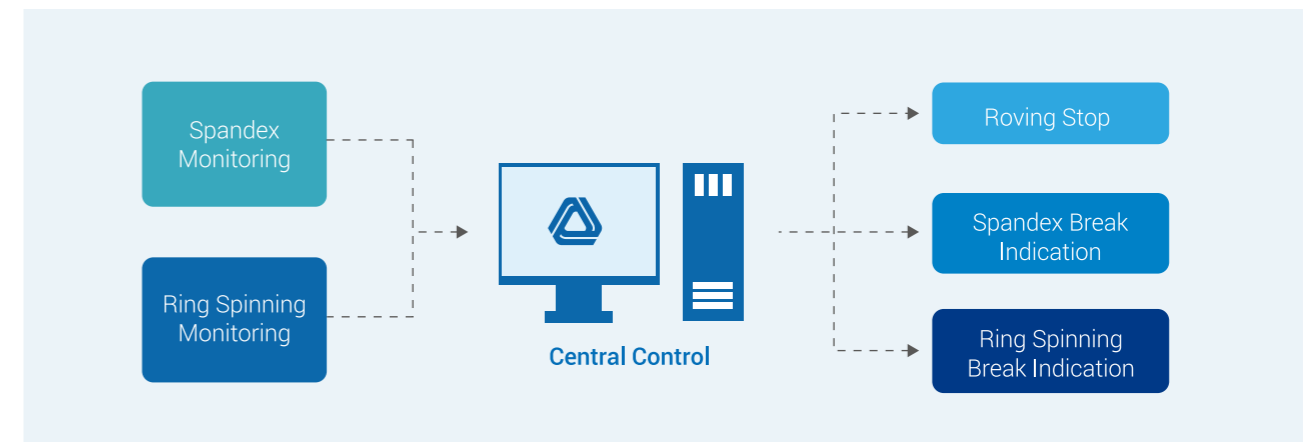

### System function

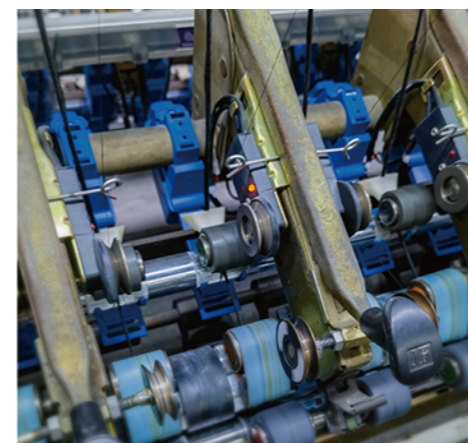

Individual spindle monitoring, efficient management, compact designing and convenient maintenance.

Count, elasticity and color of spandex or filament unlimited.

With roving stop device eliminates empty core yarn.

LED display indicates the break information from remote distance.

Anti-static treatment, reduce the accumulation of fluff.